



2008 NISSAN TOWING GUIDE

Table of Contents

Introduction	1
Towing Equipment	2
What's Right for You	3
Preparing Your Vehicle	10
Towing Safety	14
Towing Tips	17
Towing Glossary	21
Specifications	23
Protection	29
Commitment	30

INTRODUCTION

SAFETY IS PRIORITY ONE

Obviously, your first concern should be safety. Your vehicle was designed to be used primarily to carry passengers and cargo. Always remember that towing a trailer places additional loads on your vehicle's engine, drivetrain, steering, braking, and other systems. Therefore, be certain that your vehicle can meet the demands of the towing application you have in mind.

Rent or purchase only the highest-quality towing and safety equipment you can find. Reinforced tow hitches designed especially for certain Nissan vehicles are available from your Nissan dealer.* Hitches for the other Nissan models should be bought from and installed by a professional supplier of towing equipment.

Finally, it is important to follow the towing capacity limit set for your specific vehicle, and to ensure that your vehicle is in top mechanical condition, especially the tires, brakes, suspension, and engine cooling system. See your vehicle owner's manual for details.

NEVER EXCEED THE ESTABLISHED TOWING CAPACITY

Towing capacities vary from vehicle to vehicle. See the SPECIFICATIONS section of this guide for the towing capacities of 2008 Nissan vehicles produced at the time of Towing Guide publication. Use this data to help select the proper Nissan vehicle to meet your anticipated towing needs, and refer to it when renting a trailer or other piece of towing equipment.

EQUIP YOUR NISSAN FOR TOWING

The frequency and type of towing should influence the manner in which you equip your vehicle. If you plan to tow often, either for recreation or work, select the engine size, transmission type, suspension, and towing capacity that are best suited to your requirements. This guide can help you select that equipment.

If, on the other hand, your towing will be infrequent, choose the Nissan vehicle and equipment that best meets your day-to-day needs. Be careful not to exceed the towing capacity on those few occasions when you do tow.

READ THIS GUIDE BEFORE YOU TOW

This guide was designed to provide an overview of safe towing practices. Here, you'll find information on towing equipment, safety, proper loading and driving techniques, towing tips, and much more.

It is also a good idea to discuss your towing requirements with either your Nissan dealer or a professional supplier of towing equipment before you equip your Nissan vehicle for towing.

*Quest tow hitch is factory installed only.

Finally, there are state and local laws on towing that you should review to ensure compliance with all regulations.

TOWING EQUIPMENT

RENTING

The first thing to keep in mind when renting a trailer is to rent only from professional companies that specialize in towing and towing equipment. More than likely, specialized companies hire professional staff that can assist you in selecting and installing the proper towing equipment for your Nissan vehicle.

When renting, make sure you have your vehicle owner's manual on hand so that you can reference the towing capacities for your specific vehicle. Never rent a trailer that exceeds these capacities, and make sure that any related towing equipment you rent will be sufficient for the loaded trailer.

While you're there, ask questions. How much does the empty trailer weigh? How much weight will the trailer hold? What is the trailer's tongue load? With what type of brakes is it equipped (if any)? All of these factors have an effect on whether your Nissan vehicle is capable of safely pulling that type of trailer or piece of equipment.

Make certain that all of the trailer stoplights, taillights, and turn signals are connected and are operating correctly, and that all safety equipments are properly installed. Check the safety chains/cables, tie-downs, etc.

For safer operation, carefully inspect the condition of the trailer and towing equipment. Specifically, check to make sure the tires are not worn excessively and are properly inflated. Make sure there are not any broken welds, missing bolts, and that the hitch components are not damaged.

Towing safety should be a high priority when choosing and renting towing equipment, including hitches. **NEVER RENT A CLAMP-ON-TYPE HITCH.** Your vehicle's bumpers are not designed for using this type of hitch. Using it will damage your vehicle and could even result in the trailer separating from the towing vehicle; this can cause death or serious injury. To avoid this, use only a permanent-type hitch.

PURCHASING

If you are buying a travel or boat trailer, be sure that your Nissan vehicle has the towing capacity to pull it. See the SPECIFICATIONS section of this guide or refer to your vehicle owner's manual for detailed information regarding the towing capacity of your specific vehicle.

Your vehicle owner's manual should ALWAYS be referenced before making any towing decisions.

Naturally, you will want to buy the highest-quality equipment you can find for maximum towing safety. And if you plan to tow often, consider convenience. Quick-disconnect trailer light connectors and ratchet-type tie-downs, for example, make the job go faster and easier and are usually worth the extra small investment. Purchase towing items such as hitches and hitch balls only from your Nissan dealer or a professional supplier of towing equipment.

If you are intending to use your vehicle to tow a trailer you already own, you must ensure that your loaded trailer remains well within your vehicle's towing capacity as specified in the vehicle owner's manual. In addition, you should purchase the right type, style, and class* of hitch and towing equipment to properly adapt the trailer to your vehicle.

WHAT'S RIGHT FOR YOU

TYPES OF EQUIPMENT

Towing requires a variety of equipment, and, depending upon the application, there can be several types or styles of each piece of equipment. Working with your Nissan dealer or a professional supplier of towing equipment, it should be relatively simple to determine the proper type of equipment for your specific vehicle given the intended application. This section explains the most common pieces of towing equipment available.

HITCHES

Whichever type of hitch you use, it should be firmly bolted to your vehicle, and should be of the appropriate weight class for the equipment you intend to tow. In addition, keep the following in mind:

- ◆ Do not modify the vehicle's braking or exhaust systems or its body structure/frame when installing the hitch.
- ◆ Be sure that the hitch does not interfere in any way with the vehicle's impact-absorbing bumper.
- ◆ Regularly check to see that all hitch-mounting bolts are securely fastened.
- ◆ Where practical, remove the hitch when not in use. Your Nissan dealer can assist you in hitch removal and reinstallation.

*See the SPECIFICATIONS section of this guide for equipment class information specific to your vehicle.

- ◆ For receiver-type hitches using a ball mount, the ball mount should be removed when not towing.
- ◆ If you install a hitch yourself, remember that it must be securely attached to the frame or underbody, according to the manufacturer's instructions. **Never attach a hitch or towing device to the vehicle axle housing. This may damage the housing, wheel bearings, wheels, or tires.**

Hitch Types

Bumper Hitch – This is a special reinforced bumper designed to accommodate a hitch ball.

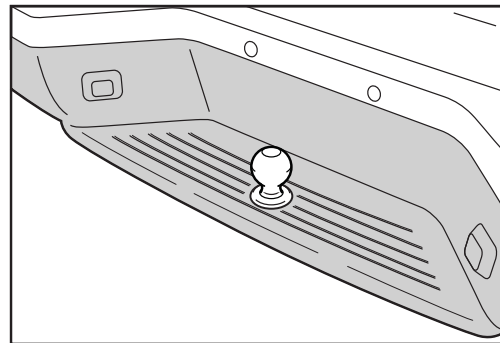

Receiver Hitch – A receiver hitch is bolted directly to the vehicle structure for added strength and durability. Nissan bolt-on receiver hitches are designed specifically for Nissan vehicles and include the necessary reinforcements, with ample clearance around bumpers, frame members, etc. These hitches allow for the removal of the ball mount when not towing.

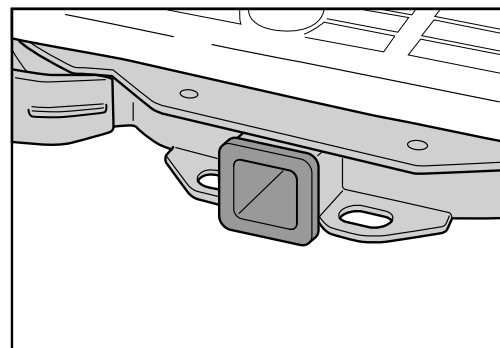

Weight-Distributing Hitch System – This type of system uses a “load-leveling” or “equalizing” hitch. The weight-distributing feature helps shift trailer tongue weight to all trailer tires and the tow vehicle front tires.

For Armada, Frontier, Pathfinder, and Titan vehicles, a weight-distributing hitch ball mount (Class IV) **IS REQUIRED** if you plan to tow trailers with a maximum weight over 5,000 lbs.

This ball mount includes a $2\frac{5}{16}$ " hitch ball rated for up to 10,000 lbs., and is available through your Nissan dealer.

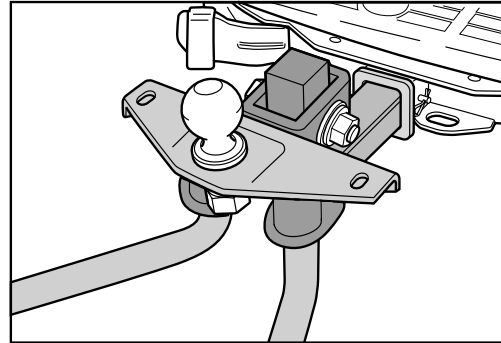

Clamp-On Bumper Hitch – This is a temporary hitch that clamps onto the bumper assembly. **DO NOT USE** this type of hitch on any Nissan vehicle because using it may result in the trailer separating from the towing vehicle; this can cause death or serious injury. Use of this type of hitch can also damage the towing vehicle.

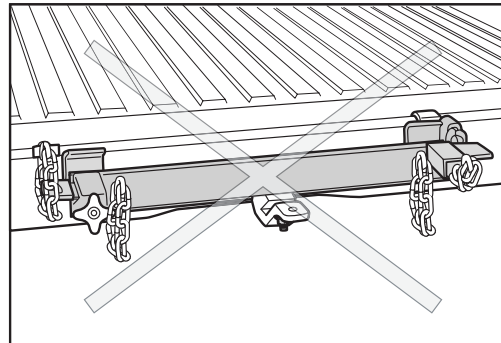

5th Wheel or Gooseneck Hitch – Mounted in the bed of a pick-up and designed for heavy-duty applications, these types of hitches are not available from Nissan but can be purchased from a professional supplier of towing equipment.*

A 5th wheel or gooseneck hitch is usually installed and adjusted to meet the requirements of a particular trailer, but two basic rules hold true in every case. First, the hitch should be mounted a minimum 2 inches forward of the rear axle centerline. Second, it should be securely attached directly to the truck frame. This installation should be done by professionals only, as it is very important to mount the hitch correctly to distribute the king pin load for the proper load carrying and sway control performance.

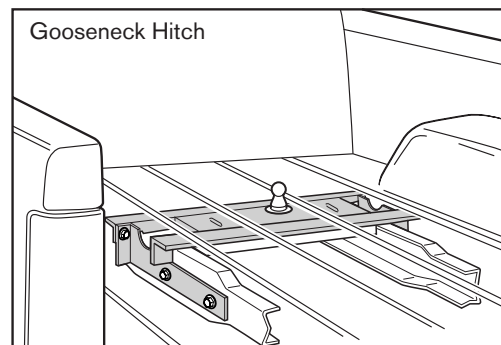
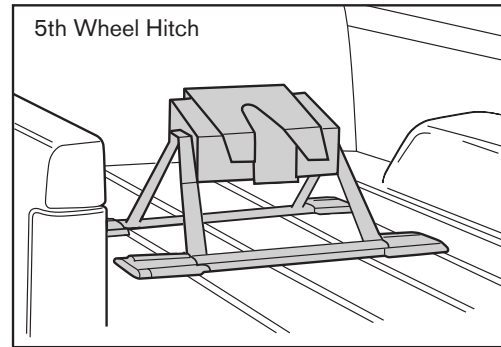

BALL MOUNT

A ball mount (also known as a drawbar or “stinger”) is a bar that holds a hitch ball and is inserted into a receiver-type hitch. Ball mounts come in a number of weight capacities (3,500 lbs., 5,000 lbs., etc.) and sizes (1¹/₄”, 2”, etc.), and can be weight-distributing or non-weight-distributing.

HITCH BALL

A hitch ball is bolted through a ball mount or a hitch hole in the tow vehicle’s rear bumper. The coupler on the trailer tongue attaches over the hitch ball.

Like ball mounts, hitch balls are available in a number of weight capacities and sizes. Always make sure the hitch ball selected has the proper shank diameter and weight rating for the ball mount as well as the coupler on your trailer. Using a 1⁷/₈” hitch ball in a 2” coupler, for example, could result in the trailer separating

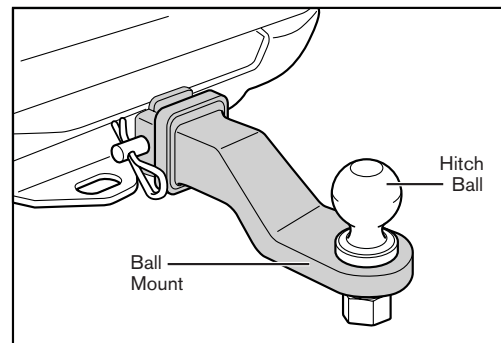

***At this time, Titan is the only Nissan vehicle approved for 5th wheel and gooseneck trailer towing. See your vehicle owner’s manual for details.**

from the tow vehicle.

The diameter of the hitch ball shank must be matched to the ball mount hole diameter. The shank should be no more than $\frac{1}{16}$ " smaller than the hole.

To keep the hitch ball in top condition, a simple maintenance routine is recommended. Coating it with light grease will minimize wear of both the coupler and hitch ball. Also, by removing the hitch ball when not towing, or by protecting it with a special cover, you will help prevent rust from forming on it.

TRAILER TONGUE

The tongue is the part of the trailer that extends forward to meet the tow vehicle, and it also carries the coupler assembly. Knowledge of the trailer tongue load (conventional trailers) and king pin load (5th wheel and gooseneck trailers) is critical as it can have a significant effect on the handling of the tow vehicle. See the SPECIFICATIONS section of this guide or refer to your vehicle owner's manual to view the maximum conventional trailer tongue load listed for your vehicle.

SAFETY CHAINS/CABLES

Always use suitable safety chains/cables between the tow vehicle and the trailer. If the hitch should break or become disengaged for some reason, these chains/cables will provide an emergency connection between the vehicle and the trailer.

The chains/cables should be crossed under the trailer tongue and attached to the hitch or vehicle frame. Crossing the chains/cables under the tongue will help prevent the tongue from hitting the ground should the trailer become disconnected.

Be sure to leave enough slack in the chains/cables to turn corners without binding; however, note that excessive slack will allow the chains/cables to drag on the ground.

Do not use S-hooks for attaching, as they may become un-hooked and are illegal in many states. To avoid damage

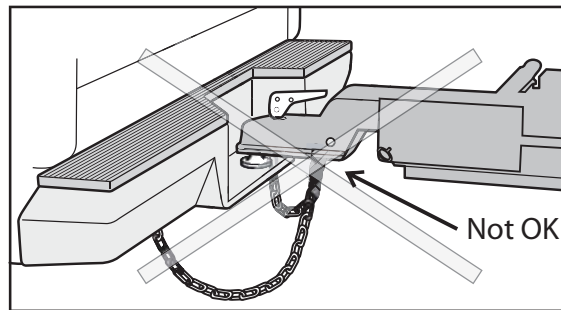
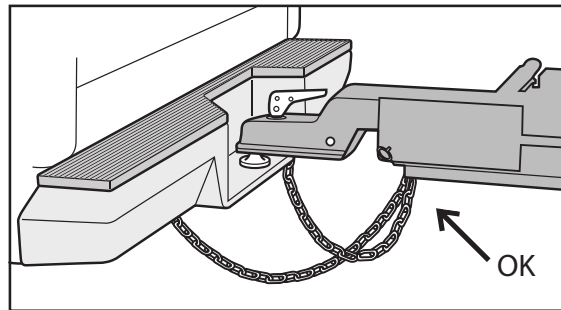

to the bumper and chains/cables when making a sharp turn, do not attach the chains/cables too close to the coupler. Consult your trailer manufacturer for the proper location of the chain/cable attachment to the trailer.

REAR VIEW MIRRORS

In many cases, a trailer can block your rear vision when you're using only the standard Nissan rear view mirrors. These mirrors were not designed for towing. "Extended" mirrors specifically designed for trailer towing should be used when your rearward vision is obstructed. Before using these mirrors, make certain that they comply with state and local regulations.

Telescoping Tow Mirrors are available as an accessory for Armada and Titan vehicles. Contact your Nissan dealer for details.

BREAKAWAY SWITCH

On a trailer with electric brakes, a breakaway switch can automatically activate the trailer brake system if the trailer becomes separated from the tow vehicle. Should the trailer become detached, a breakaway switch may help prevent the trailer from wandering into another lane and will bring it to a safer stop with less damage.

A breakaway switch relies on the power of a trailer battery, so make sure it is not discharged.

Never use the breakaway switch to "park" the trailer on a grade. The battery would eventually discharge and release the brake, allowing the trailer to roll.

Be sure to leave enough slack in the tether on the breakaway switch to turn corners without binding. If you do not, the electric trailer brakes will lock-up and not release. See your trailer manufacturer for proper installation of a breakaway switch that is compatible with your trailer braking system.

TRAILER LIGHTS

Trailer lights should comply with all applicable federal, state, and local regulations, and should be in proper working order at all times. A trailer's taillights, stoplights, and turn signals must be wired* into the tow vehicle's electrical system. Many trailers use the same filament of a dual-filament bulb for both stoplights and turn signals. The second filament is used for the trailer's taillights. All Nissan vehicles utilize separate filaments for each function. Direct splicing of this type of trailer lighting may cause damage to your vehicle's electrical system and malfunction of the trailer lighting. When connecting your Nissan vehicle to this type of trailer lighting system,

*See the SPECIFICATIONS section of this guide for wiring harness information specific to your vehicle.

a 3-wire to 2-wire power converter* must be used. A power converter of this type creates only minimal additional demand (draw) on the vehicle lighting circuits to power the trailer lighting.

Always check for correct operation of the turn signals, stoplights, and taillights every time you connect a trailer for towing. Never replace vehicle fuses with fuses of a higher amperage rating than the original.

NOTE – Improper or poor quality trailer harness wiring may affect your vehicle's electrical system. Use only a Nissan approved wiring harness, or consult your dealer or a professional supplier of towing equipment for compatible equipment.

BRAKES

As with hitches, several types of braking systems are available. Most states require a separate braking system on trailers with a loaded weight above a specific amount, therefore you should check to ensure you comply with all regulations.

NOTE – **Never connect a hydraulic trailer brake system directly to the vehicle hydraulic brake system.**

Surge Brakes – The surge brake is mounted on the trailer tongue with a hydraulic line running to each trailer wheel. Surge brakes are activated by the trailer pushing against the hitch when the tow vehicle is braking. Hydraulic surge brakes are common on rental trailers and some boat trailers. In this type of system, there is no hydraulic or electric connection for brake operation between the tow vehicle and the trailer.

Electric Trailer Brakes – Electric braking systems are activated by an electronic signal sent from a trailer brake controller (special brake-sensing module).

If electric trailer brakes are used, Nissan recommends all-electronic actuation because with this system it will not be necessary to tap into the tow vehicle's hydraulic system.

For your convenience, Armada, Frontier, Pathfinder, and Titan vehicles are pre-wired to accommodate most popular electric trailer brake controllers. A wiring harness** is either included with your vehicle or available from your Nissan dealer. This harness provides electric trailer brake controller input and output connections to the vehicle wiring. See a professional supplier of towing equipment for electric trailer brake controller availability.

NOTE – Improper or poor quality trailer harness wiring may affect your vehicle's electrical system. Use only a Nissan approved wiring harness, or consult your dealer or a professional supplier of towing equipment for compatible equipment.

*Armada LE, Frontier, Pathfinder, and Titan vehicles are pre-wired for trailer lighting and do not require a converter.

**See the SPECIFICATIONS section of this guide for wiring harness information specific to your vehicle.

SWAY CONTROL DEVICE

Sudden maneuvers, wind gusts, and buffeting caused by other vehicles can affect trailer handling. Sway control devices may be used to help control these affects. If you choose to use one, contact a reputable trailer hitch supplier to make sure the sway control device will work with the vehicle, hitch, trailer and the trailer's brake system. Follow the instructions provided by the manufacturer for installing and using the sway control device.

GENUINE NISSAN PARTS AND ACCESSORIES

Whether you'll be towing occasionally or on a regular basis, Nissan offers a full range of Genuine Nissan Parts and Accessories to help you tow with confidence.

Every accessory is thoroughly tested and inspected for fit and workmanship. Therefore, you can be certain that every item is designed to be compatible with the standard features of your vehicle and designed to assist you with your towing needs.

Contact your Nissan dealer for more information on accessories or towing-related parts for your Nissan vehicle.

PREPARING YOUR VEHICLE

BREAK-IN AND MAINTENANCE SCHEDULE

Nissan recommends that you allow a sufficient "break-in" (500 miles) of both the engine and drivetrain before towing with your new Nissan vehicle. In addition, for the first 500 miles that you tow a trailer, do not drive over 50 mph and do not make starts at full throttle.

Keep in mind, too, that towing places higher demands and added loads on vehicle components, so more frequent maintenance is called for. Your Nissan Service & Maintenance Guide provides the accelerated maintenance schedule for towing purposes. Engine oil, filter, transmission oil, and possibly other fluids should be changed more frequently when towing.

MEASURING VEHICLE WEIGHT

The key to safe, efficient towing has to do with weight. Your vehicle — SUV, truck, minivan, or passenger car — is capable of carrying and towing only a certain amount of weight. You must compare your vehicle's tow weight ratings with the combined weight of the vehicle, trailer, and their contents. This will help ensure that the total weight does not exceed any of your vehicle's

tow weight ratings. There are four weights to consider when towing:

- ◆ Gross Vehicle Weight
- ◆ Gross Axle Weight (Front and Rear)
- ◆ Gross Combined Weight
- ◆ Trailer Tongue/King Pin Load

These ratings are based upon normal highway driving and may be reduced if operating in reduced-traction situations, for example, slippery boat ramps.

NOTE – Attempting to tow loads greater than the GVWR, GAWR, GCWR, and the trailer tongue/king pin load specified could adversely affect vehicle handling, braking, and performance. Damage to your vehicle resulting from overloading may not be covered by your vehicle warranty.

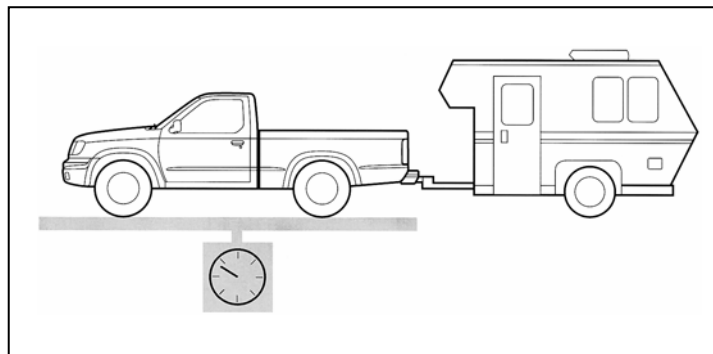

GROSS VEHICLE WEIGHT (GVW)

The Gross Vehicle Weight (GVW) is the total weight of the vehicle, plus passengers, cargo, fuel, hitch, trailer tongue/king pin load, and any optional equipment.

The best way to determine the GVW is by having the vehicle — loaded and ready to tow — weighed at a public scale. To that figure, add the combined weight of all passengers. Then, add the trailer tongue/king pin load to determine the approximate GVW. **The GVW you come up with must not exceed the Gross Vehicle Weight Rating (GVWR) for your vehicle.**

On all Nissan vehicles, the GVWR is shown on the Federal Motor Vehicle Safety Standard (F.M.V.S.S.) certification label located in the driver's-side door area.

To avoid overloading the vehicle, be sure to include the trailer tongue/king pin load as a part of the cargo when determining how much weight can be safely carried inside the vehicle. The weight of the roof rack cargo should also be included.

**F.M.V.S.S.
Certification Label**

MFD BY NISSAN MOTOR CO., LTD

DATE		
GVWR		
GAWR FR.		
WITH	RIMS AT	TIRES PSI
COLD SINGLE		
GAWR RR.		
WITH	RIMS AT	TIRES PSI
COLD SINGLE		

THIS VEHICLE CONFORMS TO ALL APPLICABLE FEDERAL MOTOR VEHICLE SAFETY STANDARDS IN EFFECT ON THE DATE OF MANUFACTURE SHOWN ABOVE. SEE OWNERS MANUAL FOR ADDITIONAL INFORMATION.

TYPE: TRUCK	
MODEL: 3B000	
COLOR	TRIM TRANS
AXLE	ENGINE

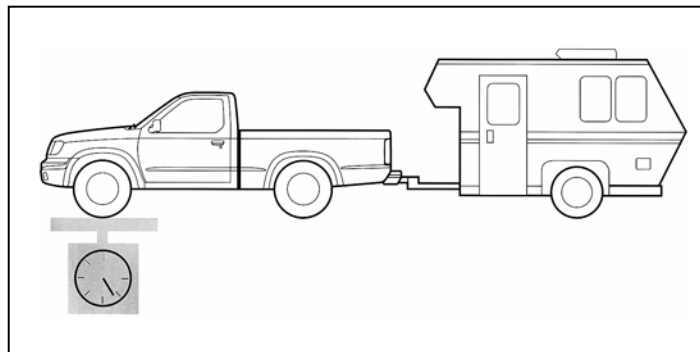

GROSS AXLE WEIGHT (GAW)

The Gross Axle Weight (GAW) is the maximum weight each axle (front and rear) is designed to safely carry.

To determine the GAW, load the vehicle as you would for towing and attach the loaded trailer. At a public scale, with the loaded trailer attached, place only the tow vehicle front wheels on the scale to determine the actual **front axle GAW**. To obtain the **rear axle GAW**, place all four tow vehicle wheels on the scale. From that figure, subtract the **front GAW** and you've got the **rear GAW** amount.

The **GAW** you come up with must not exceed the **Gross Axle Weight Rating (GAWR)** for your vehicle. On Nissan vehicles, the GAWR for both axles is listed on the F.M.V.S.S. certification label.

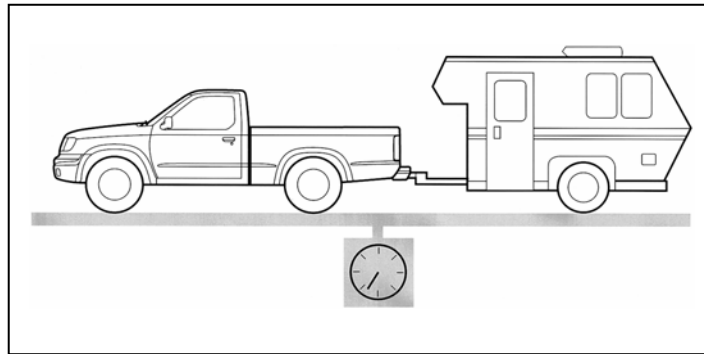

GROSS COMBINED WEIGHT (GCW)

The Gross Combined Weight (GCW) is the total weight of the tow vehicle with all passengers, cargo, and fuel, **plus** the total weight of the trailer and all its cargo.

To determine the GCW, simply weigh your vehicle when fully loaded and ready to tow, and add in the weight of the loaded trailer.

The **GCW you come up with must not exceed the Gross Combined Weight Rating (GCWR) for your vehicle.** See the SPECIFICATIONS section of this guide or refer to your vehicle owner's manual to view the GCWR listed for your vehicle.

TRAILER TONGUE/KING PIN LOAD

The amount of weight pressing down on the tow vehicle hitch is called *trailer tongue load* (conventional trailer) or *king pin load* (5th wheel or gooseneck trailers).

To measure trailer tongue/king pin load, place the tongue of the trailer on a scale when the trailer is not attached to the vehicle. A separate vehicle jack — not the trailer jack — should be used, as the location of the trailer jack is rearward of the trailer tongue and will not give you an accurate measurement of the true tongue/king pin load. Make sure the vehicle jack is placed directly under the

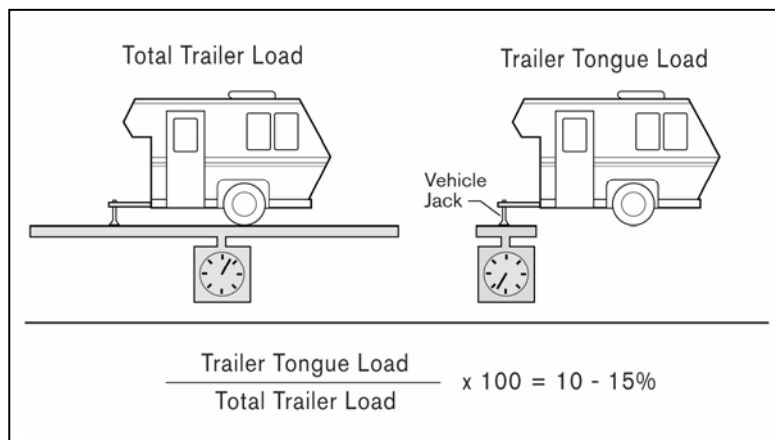

trailer tongue coupler, and the tongue is set at the height/level of the tow vehicle hitch.

For proper handling, you must keep conventional trailer tongue load between 10-15% of the actual trailer weight, within the limits of the maximum trailer tongue load allowable. For

example, to determine the proper trailer tongue load for a 1,500-lb. trailer, multiply the weight of 1,500 lbs. by 10% to arrive at a figure of 150 lbs.

5th wheel and gooseneck trailer king pin load must be kept between 15-25% of the actual trailer weight, within the limits of the king pin load allowable.

See the SPECIFICATIONS section of this guide or refer to your vehicle owner's manual to view the maximum conventional trailer tongue load listed for your vehicle.

NOTE – The vehicle weight ratings (GVWR, GAWR, GCWR, etc.) must not be exceeded, regardless of trailer or hitch type.

HITCH & TRAILER HEIGHT

It is important that your trailer floor and tongue ride as level as possible. This will help prevent over-angling, bottoming-out, and improper load transfer. Therefore, the hitch or trailer tongue must be adjusted during the initial vehicle/trailer fit-up to ensure a level ride. Ball mounts are available in different configurations to adjust the hitch ball height.

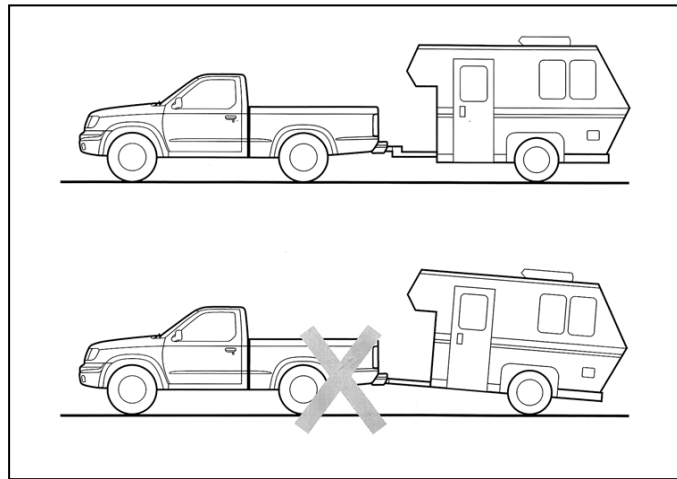

TIRE PRESSURE

When towing a trailer, increase tow vehicle tire pressures to the recommended cold specifications. You will find these figures in the vehicle owner's manual and on the tire pressure chart located in the vehicle. Trailer tire condition, size, load rating, and inflation pressure must be in accordance with the trailer and tire manufacturer's specifications.

TOWING SAFETY

Towing can dramatically alter the handling and performance characteristics of your vehicle. Plus, it puts increased strain on the engine and drivetrain. Therefore, it is always a good idea to approach towing from the standpoint of safety — whether you're purchasing equipment or actually pulling the trailer.

Always make sure your vehicle's towing capacity is adequate for the trailer you intend to tow. Buy or lease only quality equipment, and have it installed only by professionals. In addition, be certain that you have all of the equipment needed for safe towing, including safety chains/cables, electric trailer brakes, electric trailer brake controller, breakaway switch, extended rear view mirrors, and so on. All of these items have been discussed in a previous section of this guide.

With regard to vehicle maintenance, you should follow a more frequent schedule and check fluid levels, pressures, tire condition, etc., more often when on the road. See your vehicle owner's manual for details.

LOADING YOUR TRAILER

Taking the time to load and balance your trailer properly will improve overall handling and minimize the strain on your tow vehicle. Incorrectly loaded trailers tend to sway or swing from side to side, upsetting vehicle handling. Careful loading and balancing can help eliminate these problems.

As mentioned earlier, conventional trailer tongue load must fall between 10-15% of the total trailer weight. King pin load — if using a 5th wheel or gooseneck trailer — must be between 15-25% of the total trailer weight.

Excessive tongue/king pin load can actually push down the vehicle in back, lifting the front wheels to a point where traction, steering response, and braking are severely reduced. Insufficient tongue/king pin load can cause instability, which may lead to "tail wagging" or jackknifing.

With this in mind, proper loading is extremely important. When loading a trailer, 60% of the total cargo weight should be positioned in the front portion of the trailer and 40% in the back. Then, the load should be adjusted until the proper tongue/king pin load ratio is achieved.

The trailer load should be balanced equally from side-to-side. Unequal side-to-side loading can negatively affect handling and braking. Once in place, all cargo should be firmly secured to prevent shifting. If the load should shift abruptly during braking or cornering, it could quickly affect

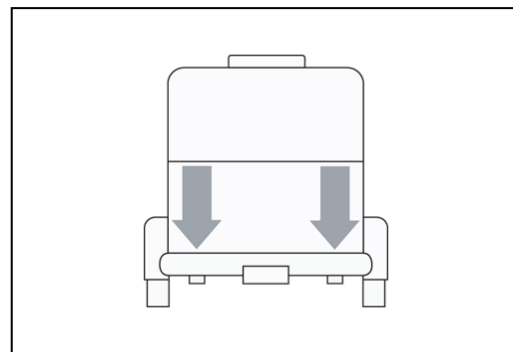
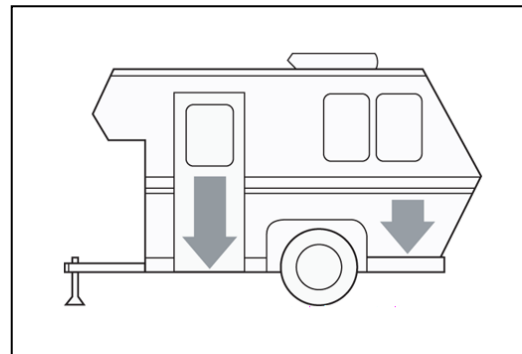

the handling of your vehicle and cause a very unsafe situation.

Finally, do not carry flammable materials, such as gasoline, in your trailer. In the event of an accident, an explosion or fire could occur.

ENSURING VEHICLE/TRAILER STABILITY

Improper loading, excessive or insufficient trailer tongue/king pin load, overloading, excessive trailer weight, poorly designed trailer suspensions, crosswinds, and poor maintenance are all things that can affect the stability of your vehicle and trailer combination.

If swaying does occur, check the cargo load for proper balance and distribution to ensure proper trailer tongue/king pin load. In addition, check the condition of the suspension and shocks, as well as the tires, tire pressures, and wheel bearings on both the tow vehicle and the trailer. If swaying occurs because of high winds or poor weather conditions, wait until these conditions improve before resuming your trip.

If the swaying continues and you feel your trailer is suitably balanced and within the towing capacity limits of your vehicle, discontinue towing and consult your Nissan dealer or trailer manufacturer to determine the problem. Most important, do not tow until the problem is corrected.

VEHICLE SPEED

Some states have specific regulations and speed limits for vehicles that are towing trailers. Always obey these ordinances.

Remember to reduce your speed in unsafe or less-than-ideal road conditions or weather. When towing a trailer, braking distances increase while handling agility decreases. Always leave yourself an extra margin of distance to respond to emergency situations.

PASSENGERS

Never allow passengers to ride inside a trailer while it is being towed. Not only is this unlawful in most areas, passengers could be seriously injured during sudden trailer movement or in an accident. In addition, trailers may allow fumes from the tow vehicle to leak inside. This could result in carbon monoxide poisoning from the engine exhaust.

VEHICLE MODIFICATIONS

Vehicle modifications — beyond those required for proper hitch installation, wiring hook-up, and necessary cooling system upgrading — are not recommended for any Nissan vehicle being used for towing purposes. Changes to the drivetrain, suspension, exhaust systems, frame structure/unibody, or other vehicle components are not necessary for towing within the

limits described in this guide. These changes may diminish the reliability and longevity of your vehicle and possibly void warranty coverage.

TOOL KIT

It is always a good idea to travel with a special tool kit when towing. In addition to tools, it should contain flares, a flashlight, emergency reflectors, jumper cables, extra fuses, extra radiator coolant, oil, and easily replaced spare parts such as taillight bulbs. You should also carry spare tires for your tow vehicle and trailer, as well as a jack suitable for use on the trailer. Be aware that not all automotive jacks can be used safely on a trailer.

BEFORE STARTING OUT

Before starting out on a trip, make one last inspection of the tow vehicle and the trailer. Are the tire pressures correct? Are the safety chains/cables securely in place? Is the cargo tied down securely? Do all the lights work? Is the coupler properly attached over the hitch ball and secured using a locking pin? Is the breakaway switch hooked up and functioning properly? Are vehicle and electric trailer brakes working properly?

Make a checklist of key items to be inspected, and don't forget the basics. When towing, vehicle engine oil, transmission oil, and coolant should always be checked before starting out. Finding a potential problem while in your driveway is better than discovering it miles from home.

TOWING TIPS

If you've never towed a trailer before, be aware that it does take getting used to. To begin with, towing noticeably affects your vehicle's performance:

- ◆ It will not accelerate as quickly — an important point to keep in mind when merging onto a highway.
- ◆ It will not stop as quickly. Leave more room than usual between you and the traffic ahead, and brake sooner when coming to a stop.
- ◆ Abrupt maneuvering can unbalance the load and reduce the handling stability of your tow vehicle. Plan ahead and make lane changes and turns smoothly.

If possible, before you actually hit the open road, practice towing in a large uncrowded area such as a stadium or shopping center parking lot. Become especially familiar with backing up a trailer — the maneuver many people find most difficult.

REDUCE SPEED

Drive your vehicle at a moderate speed, and remember to reduce your speed in unsafe or less-than-ideal road conditions or weather. The tendency for a trailer to sway increases with speed, and such swaying can result in a loss of control.

BRAKE SOONER

The combination of your tow vehicle and trailer obviously requires a greater distance to stop. A good rule of thumb to remember is that for each 10 mph of speed, allow yourself one tow vehicle and trailer length of distance between the front of your vehicle and the vehicle ahead.

When braking, use firm but gradual pressure on the pedal rather than panic braking. Applying the brakes abruptly or with too much force can cause the trailer to skid or jackknife at its point of attachment with the vehicle. This, in turn, can throw the tow vehicle out of control. If equipped with an electric trailer brake controller, follow the recommended operational instructions.

PASS CAREFULLY

As mentioned in the introduction to this section, because of the added weight of the trailer, acceleration capability is reduced and you'll require a longer distance to pass another vehicle. Be certain you have sufficient time and space to pass safely. Obviously, never attempt passing on hills or when going around curves.

CORNER MORE SLOWLY

Know your vehicle and trailer capabilities. Entering a sharp corner too quickly or abruptly can "crack the whip," whereby the trailer can actually pull the tow vehicle off the road. Therefore, when approaching a relatively sharp corner, begin braking sooner than you would when not towing. Do your braking in a straight line prior to the corner, and turn smoothly into it. In addition, remember to make a wider turn than normal to ensure that the trailer safely clears the inside of the turn.

When towing a 5th wheel or gooseneck trailer, do not make sharp turns while driving or backing as the trailer may contact the vehicle and cause damage to both the trailer and vehicle. A special extended 5th wheel pin box or sliding hitch may be required to provide additional trailer-to-truck clearance for tight maneuvering.

BACK UP WITH CAUTION

Backing up with a trailer is a difficult maneuver; however, there is a "trick" that can simplify the procedure considerably. Simply steer with one hand at the bottom of the steering wheel. To turn the trailer to the left, first move the steering wheel to the left. To turn the trailer to the right,

move the wheel to the right. All movements of the wheel should be done in small increments. Of course, backing up should be done only at very slow speeds. For large trailers that obstruct your rearward vision, have someone outside the vehicle act as a “spotter” to guide you along.

PARK SMART

A tow vehicle and trailer can be an unwieldy combination in a small area, so always try to park where you will have a relatively easy time maneuvering. Once parked, always block the wheels on both the tow vehicle and the trailer.

Parking on a slope is not recommended. If, however, you must park on a slope and your vehicle is equipped with an automatic transmission, there are some precautions you should take:

- ♦ Have someone block the wheels once the tow vehicle and trailer are in position and being held by the vehicle's brake.
- ♦ Next, apply the parking brake and only then move the gear lever into PARK. If you move the lever into PARK before blocking the wheels and applying the parking brake, transmission damage may occur.

HIGH-ALTITUDE PERFORMANCE

An engine will lose about 4% of its performance for every 1,000 feet above sea level that you travel. If you will be towing in high altitudes, it is a good idea to allow more time than usual due to the engine's reduced performance.

TOW MODE (IF EQUIPPED)

Tow Mode should be used when the vehicle and trailer weight is at least 75% of the vehicle GCWR. This mode is most useful when towing a heavy trailer or hauling a heavy load, particularly when stop-and-go traffic, rolling terrain, or a busy parking lot is involved.

Driving the vehicle in Tow Mode with minimal trailer load will not cause any damage; however, fuel economy may be reduced and transmission/engine driving characteristics may feel different.

HILLS – UPGRADES

As the incline increases, shift down to a lower gear to maintain speed and prevent the engine from lugging. However, for long and steep grades, do not stay in first gear when driving above 35 mph or in second gear above 58 mph. The added weight of a trailer places an increased load on the engine and cooling system, so monitor your coolant temperature gauge and

automatic transmission fluid temperature gauge (if equipped) very carefully. At the first sign of overheating, pull to the side of the road. See IF YOUR ENGINE OVERHEATS later in this section for more information.

HILLS – DOWNGRADES

While going downhill, the weight of the trailer pushing on the tow vehicle may decrease overall stability. Therefore, to maintain adequate control, reduce your speed and shift to a lower gear.

Avoid long or repeated use of the brakes when descending a hill, as this reduces their effectiveness and could cause overheating. Shifting to a lower gear instead provides “engine braking” and reduces the need to brake as frequently.

AUTOMATIC CRUISE CONTROL

Do not use cruise control while towing a trailer.

IF YOUR ENGINE OVERHEATS

A moderate increase in engine operating temperature is normal when towing a trailer. If, however, the coolant temperature gauge reading is abnormally high, or if you are experiencing a significant loss of power, or if you hear unusual engine noises,* the engine may be overheating and you should immediately take the following steps:

1. Pull your vehicle safely over to the side of the road, out of traffic. Apply the parking brake and move the gearshift lever to NEUTRAL (manual) or PARK (automatic). **DO NOT STOP THE ENGINE.**
2. Turn off the air conditioning and, after opening all the windows, turn the heater on to maximum hot and the fan to its highest speed. The heater core in your vehicle is just like a miniature engine radiator and will provide an extra cooling surface to help reduce engine temperature.
3. Run the engine at a fast idle (approximately 1,500 rpm) until the temperature gauge returns to a normal reading. If the temperature does not drop or continues to increase, stop this step immediately.
4. Being cautious of traffic, step out of the vehicle and, from a safe distance, look for steam underneath the engine. If you see steam or leaking coolant, stand clear to avoid being burned and shut off your engine immediately and allow it to cool. If there is no steam, open the hood. Never remove the radiator cap when the radiator is hot. If the cap is removed under these conditions, hot water under high pressure may spurt out, possibly causing

*See your vehicle owner’s manual for additional indications that your vehicle may be overheating.

serious injury.

5. As soon as the engine has cooled to its normal operating temperature, visually inspect the drive belts for damage or looseness. A loose belt reduces water pump efficiency. Be careful to keep your hands, hair, jewelry, and clothing clear of the running drive belt and other moving parts when inspecting the engine and radiator. Also check to see if the cooling fan is running, and inspect the water pump, radiator, and radiator hoses for leaks. Keep in mind, too, that if your vehicle is equipped with an electric fan motor, it may start without warning any time the coolant temperature is high. If you find leaking coolant, a loose or missing drive belt, or an inoperable fan, turn off the engine immediately.
6. If no leaks are apparent and all other components appear to be operating properly with the engine cooled to its normal operating temperature, check the coolant level in the reservoir tank with the engine running. Add coolant to the reservoir tank if needed. At this point, if repairs are required, go to the nearest Nissan dealer. See the IN CASE OF EMERGENCY section of your vehicle owner's manual for additional information on overheating.

NOTE – Armada, Frontier, Pathfinder, and Titan vehicles have an engine protection mode, which helps reduce the chance of engine damage if the engine coolant reaches a specified temperature. See your vehicle owner's manual for details.

TOWING GLOSSARY

5TH WHEEL HITCH	<i>Located just forward of the rear axle centerline, this hitch uses a king pin to serve as the pivot point for the trailer.</i>
BALL MOUNT	<i>A bar that holds the hitch ball and is inserted into the hitch receiver. Also commonly called a drawbar or "stinger."</i>
BREAKAWAY SWITCH	<i>A safety device using a trailer battery that automatically applies the trailer's brakes if it should accidentally become separated from the tow vehicle. A breakaway switch may be used with both electric or surge trailer brake systems.</i>
BUMPER HITCH	<i>A reinforced bumper designed to accommodate a hitch ball.</i>
ELECTRIC TRAILER BRAKES	<i>When the brakes on a tow vehicle are applied, an electric current is sent to an actuator which applies the trailer's brakes.</i>
ELECTRIC TRAILER BRAKE CONTROLLER	<i>A device that controls the electric trailer brakes.</i>

GOOSENECK HITCH	<i>Located just forward of the rear axle centerline, this hitch uses a ball to serve as the pivot point for the trailer.</i>
GROSS AXLE WEIGHT RATING (GAWR)	<i>The maximum amount of weight each vehicle axle (front and rear) is designed to safely carry.</i>
GROSS COMBINED WEIGHT RATING (GCWR)	<i>The maximum allowable combined weight of the vehicle and trailer, including passengers and all cargo.</i>
GROSS VEHICLE WEIGHT RATING (GVWR)	<i>The maximum allowable weight of the vehicle, including passengers, cargo, fuel, hitch, trailer tongue load, and any optional equipment.</i>
KING PIN LOAD	<i>The amount of trailer (5th wheel or gooseneck) weight pressing down on the tow vehicle hitch.</i>
HITCH BALL	<i>A ball that connects the trailer to the tow vehicle hitch and provides the means by which the trailer pivots during cornering. Available in a number of sizes and weight capacities, it must correspond to the trailer coupler size, and have a sufficient capacity rating for the trailer being pulled.</i>
RECEIVER HITCH	<i>A frame- or structure-mounted hitch with a receiver that allows removal of the ball mount.</i>
SAFETY CHAINS/CABLES	<i>Provides an emergency connection between the tow vehicle and the trailer, should the trailer become disengaged for any reason.</i>
SURGE BRAKES	<i>Hydraulic-type braking system activated by inertia. As the tow vehicle begins to brake, the trailer pushes against the hitch ball, consequently activating the trailer brakes.</i>
TRAILER TONGUE/COUPLER	<i>The part of the trailer that extends forward to meet the tow vehicle, and also carries the coupler assembly.</i>
TRAILER TONGUE LOAD	<i>The amount of trailer (conventional) weight pressing down on the tow vehicle hitch.</i>
WEIGHT-DISTRIBUTING HITCH SYSTEM	<i>Type of hitch system that helps shift the trailer tongue weight to all trailer tires and the tow vehicle front tires. Strongly recommended when towing trailers with a Maximum Trailer Weight greater than 5,000 lbs.</i>
WIRING HARNESS	<i>Provides an electrical connection linking the tow vehicle's electrical system to the trailer's system.</i>

SPECIFICATIONS

TOWING CAPACITIES

SUV's, Trucks, and Minivan

2008 ARMADA TOWING DATA			
Engine Type	5.6L V8		
Transmission	A/T		
Model(s)		2WD	4WD
Maximum Trailer Weight ^{1,4} (lbs.)	without optional tow package	6,500	6,500
	with optional tow package ⁶	9,100	9,000
Maximum Trailer Tongue Load (lbs.)	without optional tow package	650	650
	with optional tow package ⁶	910	900
Gross Combined Weight Rating (lbs.)	without optional tow package	12,800	13,000
	with optional tow package ⁶	15,100	15,100

2008 FRONTIER TOWING DATA					
Engine Type	2.5L 4-Cylinder	4.0L V6			
Transmission	A/T & M/T				
Model(s)	King Cab 2WD	King Cab 2WD	King Cab 4WD	Crew Cab 2WD	Crew Cab 4WD
Maximum Trailer Weight ^{1,3,4} (lbs.)	3,500	6,500	6,300	6,300	6,100
Maximum Trailer Tongue Load ³ (lbs.)	350	650	630	630	610
Gross Combined Weight Rating (lbs.)	7,936	11,133	11,133	11,133	11,133
Maximum Trailer Frontal Area	60 sq. ft.				

2008 PATHFINDER TOWING DATA		
Engine Type	4.0L V6	5.6L V8
Transmission	A/T	
Maximum Trailer Weight ^{1,4} (lbs.)	6,000	7,000
Maximum Trailer Tongue Load (lbs.)	600	700
Gross Combined Weight Rating (lbs.)	11,133	12,570
Maximum Trailer Frontal Area	60 sq. ft.	

2008 QUEST TOWING DATA	
Engine Type	3.5L V6
Transmission	A/T
Maximum Trailer Weight ¹ (lbs.)	3,500
Maximum Trailer Tongue Load (lbs.)	350
Gross Combined Weight Rating (lbs.)	8,500

2008 ROGUE TOWING DATA		
Engine Type	2.5L 4-Cylinder	
Transmission	CVT	
Model(s)	with Manual Shift Mode	without Manual Shift Mode
Maximum Trailer Weight ¹ (lbs.)	1,500	1,000
Maximum Trailer Tongue Load (lbs.)	150	150
Gross Combined Weight Rating (lbs.)	5,636	5,136

2008 TITAN TOWING DATA - WITH OPTIONAL TOWING PACKAGE ⁶								
Engine Type		5.6L V8						
Transmission		A/T						
Model(s)		KING CAB						
		XE		SE		PRO-4X	LE	
		2WD	4WD	2WD	4WD	4WD	2WD	4WD
Short Wheel Base	Maximum Trailer Weight ^{1,2,4,5} (lbs.)	9,500	9,400	9,500	9,400	9,300	9,200	9,200
	Maximum Trailer Tongue Load ² (lbs.)	950	940	950	940	930	920	920
	King Pin Load (lbs.)	1,425	1,410	1,425	1,410	1,395	1,380	1,380
	Gross Combined Weight Rating ⁵ (lbs.)	15,100	15,100	15,100	15,100	15,100	15,100	15,100
Long Wheel Base	Maximum Trailer Weight ^{1,2,4,5} (lbs.)	9,400	9,200	9,400	9,100	–	9,100	8,900
	Maximum Trailer Tongue Load ² (lbs.)	940	920	940	910	–	910	890
	King Pin Load (lbs.)	1,410	1,380	1,410	1,365	–	1,365	1,335
	Gross Combined Weight Rating ⁵ (lbs.)	15,100	15,100	15,100	15,100	–	15,100	15,100
Model(s)		CREW CAB						
		XE		SE		PRO-4X	LE	
		2WD	4WD	2WD	4WD	4WD	2WD	4WD
Short Wheel Base	Maximum Trailer Weight ^{1,2,4,5} (lbs.)	9,400	9,200	9,400	9,100	–	9,100	8,900
	Maximum Trailer Tongue Load ² (lbs.)	940	920	940	910	–	910	890
	King Pin Load (lbs.)	1,410	1,380	1,410	1,365	–	1,365	1,335
	Gross Combined Weight Rating ⁵ (lbs.)	15,100	15,100	15,100	15,100	–	15,100	15,100
Long Wheel Base	Maximum Trailer Weight ^{1,2,4,5} (lbs.)	9,299	9,100	9,299	9,100	8,999	9,100	8,900
	Maximum Trailer Tongue Load ² (lbs.)	930	910	930	910	900	910	890
	King Pin Load (lbs.)	1,395	1,365	1,395	1,365	1,350	1,365	1,335
	Gross Combined Weight Rating ⁵ (lbs.)	15,100	15,100	15,100	15,100	15,100	15,100	15,100

2008 TITAN TOWING DATA - WITHOUT OPTIONAL TOWING PACKAGE								
Engine Type		5.6L V8						
Transmission		A/T						
Model(s)		KING CAB						
		XE		SE		PRO-4X	LE	
		2WD	4WD	2WD	4WD	4WD	2WD	4WD
Short Wheel Base	Maximum Trailer Weight ^{1,2,4,5} (lbs.)	6,500	6,500	7,400	7,400	7,200	7,200	7,200
	Maximum Trailer Tongue Load ² (lbs.)	650	650	740	740	720	720	720
	King Pin Load (lbs.)	975	975	1,110	1,110	1,080	1,080	1,080
	Gross Combined Weight Rating ⁵ (lbs.)	12,800	13,000	12,800	13,000	13,000	12,800	13,000
Long Wheel Base	Maximum Trailer Weight ^{1,2,4,5} (lbs.)	6,499	6,499	7,101	7,101	–	7,000	6,900
	Maximum Trailer Tongue Load ² (lbs.)	650	650	710	710	–	700	690
	King Pin Load (lbs.)	975	975	1,065	1,065	–	1,050	1,035
	Gross Combined Weight Rating ⁵ (lbs.)	12,800	13,000	12,800	13,000	–	12,800	13,000
Model(s)		CREW CAB						
		XE		SE		PRO-4X	LE	
		2WD	4WD	2WD	4WD	4WD	2WD	4WD
Short Wheel Base	Maximum Trailer Weight ^{1,2,4,5} (lbs.)	6,500	6,500	7,401	7,300	–	7,101	7,000
	Maximum Trailer Tongue Load ² (lbs.)	650	650	740	720	–	710	700
	King Pin Load (lbs.)	975	975	1,110	1,095	–	1,065	1,050
	Gross Combined Weight Rating ⁵ (lbs.)	12,800	13,000	12,800	13,000	–	12,800	13,000
Long Wheel Base	Maximum Trailer Weight ^{1,2,4,5} (lbs.)	6,499	6,499	7,101	7,000	7,000	6,799	6,700
	Maximum Trailer Tongue Load ² (lbs.)	650	650	710	700	700	680	670
	King Pin Load (lbs.)	975	975	1,065	1,050	1,050	1,020	1,005
	Gross Combined Weight Rating ⁵ (lbs.)	12,800	13,000	12,800	13,000	13,000	12,800	13,000

2008 XTERRA TOWING DATA	
Engine Type	4.0L V6
Transmission	A/T & M/T
Model(s)	2WD & 4WD
Maximum Trailer Weight ¹ (lbs.)	5,000
Maximum Trailer Tongue Load (lbs.)	500
Gross Combined Weight Rating (lbs.)	9,658
Maximum Trailer Frontal Area	60 sq. ft.

- 1 Maximum Trailer Weight values are calculated assuming a base vehicle with driver and any options required to achieve the rating. Additional passengers, cargo and/or optional equipment will add weight to the vehicle and reduce your vehicle's maximum towing capacity and trailer tongue load.
- 2 The Maximum Trailer Weight when using the Genuine Nissan step bumper in this application as a ball mount is 5,000 lbs.; the Maximum Trailer Tongue Load is 500 lbs.
- 3 The Maximum Trailer Weight when using the Genuine Nissan step bumper in this application as a ball mount is 3,500 lbs.; the Maximum Trailer Tongue Load is 350 lbs.
- 4 Requires weight-distributing hitch system when towing over 5,000 lbs.
- 5 The Maximum Trailer Weight and Gross Combined Weight ratings for 5th wheel and gooseneck trailer towing are the same as specified for conventional trailer towing.
- 6 The vehicle optional tow package **does not** include a ball mount. Two ball mount options are available through your Nissan dealer:
 - ♦ Class III hitch ball mount for trailers with a Maximum Trailer Weight of **5,000 lbs. or less**.
NOTE – A hitch ball is not included with the Class III ball mount. This ball mount can be used with any hitch ball with a shank diameter of 1" or larger.
 - ♦ Class IV weight-distributing hitch ball mount for trailers with a Maximum Trailer Weight **greater than 5,000 lbs.** This ball mount can also be used with trailers under 5,000 lbs. Maximum Trailer Weight.
NOTE – The Class IV ball mount includes a 2^{5/16}" hitch ball rated for 10,000 lbs. Smaller hitch ball sizes may be used by following the instructions included in the ball mount kit.

NOTES:

- ♦ Most states require a separate braking system on trailers with a loaded weight above a specific amount. Check local ordinances.
- ♦ A/T – Automatic Transmission, CVT – Continuously Variable Transmission

Passenger Vehicles – The towing capacity for 350Z Coupe, Altima (Coupe, Hybrid, and Sedan), Maxima, and Sentra is 1,000 lbs.; the maximum trailer tongue load is 100 lbs.

DO NOT tow a trailer with 350Z Roadster or Versa.

NOTE – For passenger vehicles, the trailer tongue load must be subtracted from the GVWR as shown on the F.M.V.S.S. certification label located in the driver's-side door area.

Other Recommendations and Information – Towing performance and speed are affected by vehicle payload, tow weight, road grades, and weather conditions, including high temperatures. See your vehicle owner’s manual for details.

TOWING EQUIPMENT CLASSES

	Class I Trailer hitch equipment* can be used to tow trailers with a maximum weight of 2,000 lbs.**		Class II Trailer hitch equipment* can be used to tow trailers with a maximum weight of 3,500 lbs.**		Class III Trailer hitch equipment* can be used to tow trailers with a maximum weight of 5,000 lbs.**		Class IV Trailer hitch equipment* can be used to tow trailers with a maximum weight of 10,000 lbs.**	
	Bumper Towing	Receiver Hitch	Bumper Towing	Receiver Hitch	Bumper Towing	Receiver Hitch	Bumper Towing	Receiver Hitch
Armada								X
Frontier			X					X
Pathfinder								X
Quest				X				
Rogue		X						
Titan					X			X
Xterra						X		
Passenger Vehicles†		X						

NOTES:

- ◆ A weight-distributing hitch system is required for Armada, Frontier, Pathfinder, and Titan vehicles if you plan to tow trailers with a maximum weight over 5,000 lbs.
- ◆ You can tow a trailer with a lower rating than the hitch. For example, a Class IV hitch can tow a Class II trailer.

*Includes matched receiver, ball mount, and hitch ball.

**Towing capability of the vehicle may be less than the maximum towing rating of the equipment. See TOWING CAPACITIES earlier in this section or refer to your vehicle owner’s manual for detailed information regarding the towing capacity of your specific vehicle.

† **DO NOT tow a trailer with 350Z Roadster or Versa.**

TOW VEHICLE WIRING HARNESSES

	Harness Type	Trailer Lighting	Electric Trailer Brakes
Armada	7-pin connector wiring harness	LE: Pre-wired SE: Tow harness kit available	Pre-wired with 7-pin harness. Requires an electric trailer brake controller (supplied by customer), and an electric trailer brake controller wiring harness (included with vehicle or available from Nissan dealer).
Frontier	Receiver hitch: 7-pin connector wiring harness	Tow harness kit available	
	4-pin connector wiring harness		N/A
Pathfinder	Standard equipment: 4-pin connector wiring harness	Tow harness kit available	Pre-wired with 7-pin harness. Requires an electric trailer brake controller (supplied by customer), and an electric trailer brake controller wiring harness (included with vehicle or available from Nissan dealer).
	7-pin connector wiring harness		
Quest	4-pin connector wiring harness	Available in factory tow package	N/A
Rogue	4-pin connector wiring harness	SL: Tow harness kit available*	
Titan	7-pin connector wiring harness	Pre-wired	Pre-wired with 7-pin harness. Requires an electric trailer brake controller (supplied by customer), and an electric trailer brake controller wiring harness (included with vehicle or available from Nissan dealer).
Xterra	Receiver hitch: 7-pin connector wiring harness	Tow harness kit available	

PROTECTION

At Nissan, we back everything we build. So we're proud that every Nissan is protected by some of the best New Vehicle Limited Warranties, including 36-month/36,000-mile basic coverage. All 2008 models also feature 60-month/60,000-mile powertrain coverage.** And, Nissan warranties are completely transferable if you should sell your Nissan.

If you want additional peace of mind, we proudly offer the Nissan Security+Plus[®] Vehicle Protection Plan. This plan offers quality mechanical protection long after your New Vehicle Limited Warranty expires.

The Security+Plus Vehicle Protection Plan is backed by Nissan and designed exclusively for Nissan owners. From a variety of plans available, you can choose the one that best fits your

*Available only for SL models equipped with Manual Shift Mode.

**For complete warranty details, read the Nissan Warranty Information Booklet or see your nearest Nissan dealer.

driving needs (up to 84 months/100,000 miles!). For the maximum coverage, you will want to opt for Security+Plus Gold[®] Preferred.

Whichever plan you choose, coverage is available throughout the United States. Repair work will be done at authorized Nissan dealers by Nissan-trained technicians utilizing Genuine Nissan Parts. For more information about Security+Plus Vehicle Protection Plans, contact your participating Nissan dealer.

The quality of Genuine Nissan Parts and Accessories is backed by the integrity of a Genuine Nissan Replacement Parts and Accessories Limited Warranty. If purchased within the basic coverage period of 36 months/36,000 miles, Genuine Nissan Parts and Accessories are covered by the remaining period of the warranty. If the remaining period is less than 12 months/12,000 miles (or if the vehicle warranty has expired), then Genuine Nissan Accessories are covered by their own 12-month/12,000-mile Limited Warranty. See your Nissan Warranty Information Booklet or ask your Nissan dealer for specific details.

CONCERN FOR YOUR SAFETY

Nissan urges you to always use your seat belt whenever you drive. And please make sure all passengers are buckled up. Keep in mind that air bags are a supplemental restraint system and must always be used in conjunction with a seat belt.

In addition, a rear-facing child restraint must never be used in the front passenger seat if the vehicle is equipped with a front passenger air bag. Children 12 and under should ride in the rear seat properly secured in child restraints, booster seats, or seat belts, according to their size. See your vehicle owner's manual for more details.

COMMITMENT

At Nissan, our commitment to your satisfaction extends well beyond building a full line of quality products. It begins with people dedicated to designing vehicles to satisfy your needs. Then, building them to standards that are beyond your expectations. Our nationwide network of nearly 1,100 dealers will help you select the Nissan that is right for you.

For further assistance, search our Web site at www.NissanUSA.com. For Nissan dealer locations or for more information on this and other Nissan products, call 1-800-239-8810. Or call 1-800-NISSAN-1 for answers to product-related issues and solutions to your transportation needs.

All illustrations, photographs, and specifications in this publication are based on the latest product information available at the time of printing. Some vehicle parts cannot be shown in certain photographs. Some vehicles are shown with optional equipment. See the actual vehicle for complete accuracy. Availability and delivery time for particular models and equipment combinations may vary. Nissan North America, Inc. reserves the right to make changes at any time, without prior notice, in prices, colors, materials, equipment, specifications, and models, and to discontinue models or equipment. All specifications, options, and accessories shown in this publication apply to the 49 continental states. Specifications, options, and accessories may differ in Hawaii, U.S. territories, and other countries. For information on availability, additional options, or accessories, see your Nissan dealer.

Nissan, the Nissan Brand Symbol, "SHIFT_" and Nissan Model Name(s) are Nissan trademarks.